

The WM 561W(EN), certified under EN 54-24:2008, offers excellent audio performance with its 120 mm dual-cone full-range transducer, ideal for noisy environments. Its sleek white ABS enclosure blends well with any décor, making it suitable for schools, offices, and retail spaces. The speaker ensures clear, reliable sound and maintains a professional appearance in any setting. It also includes a ceramic connector, thermistor, and capacitor for enhanced safety and performance. The Fire Retardant ABS material further ensures compliance with high safety standards.

- 120 mm dual cone full range loudspeaker driver unit, providing clear undistorted sound quality.
- Simple installation with a choice of rear screw mounting option to eliminate front visible screws or front screw mounting.
- Built-in audio line matching transformer with multiple impedance choice of 6.7 k Ω , 3.3 k Ω and 1.7 k Ω , suitable for both 70 V and 100 V line distributed speaker system.
- Aesthetically designed and injection moulded in pure white ABS resin enables the enclosure to blend into most surroundings.
- Fire Retardant ABS Back Enclosure for enhanced safety and compliance.



WM561W(EN)

Technical Specification

WM 561W(EN)	
Rated Input	100 V : 6 W (6 - 3 - 1.5 W) 70 V : 3 W (3 - 1.5 - 0.75 W)
Rated Impedance	1.7 kΩ (1.7 - 3.3 - 6.7 kΩ)
Maximum Power	9 W
Frequency Response	120 Hz - 20 kHz
Sensitivity 1W @ 1m	93 / 101 dB
Coverage Angle (1kHz, -6dB)	106 °
Speaker Component	120 mm Dual cone Full-range Loudspeaker
Certified	EN 54-24:2008
Safety	Acc. to EN 60065
Material & Finish	Enclosure/Case: Frame: Fire Retardant ABS, white
Dimensions	193 x 184 x 84 mm (W x H x D)
Weight	1.2 kg

Frequency Response

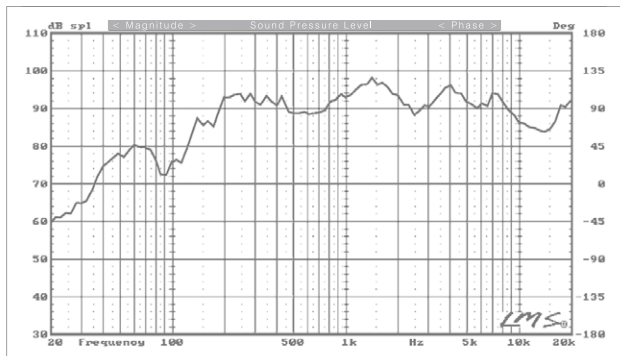

*at 1 W / 1 m

SPL Polar Plot

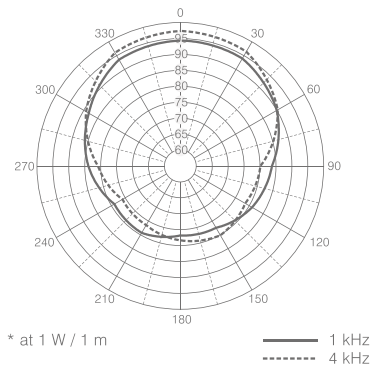

* at 1 W / 1 m

 — 1 kHz
 - - - 4 kHz
